



BONE CONDENSING

Osteotomes Kit

The Osteotome Kit offers a set of instruments of different conical geometries and progressively wider diameters. The osteotomes utilized with the Magnetic Mallet equally compress the trabecular bone laterally and apically in order to improve the density of bone for the implant osteotomy. The process is completely heat-free, therefore does not need any irrigation. Furthermore none of the bone mass is removed, resulting in an extremely bone conservative procedure.

The Osteotome Kit offers 5 different sizes and the same instruments curved for better access to the posterior regions for a total of 10 instruments. 3 additional sizes are available as “special instruments” for a total of 8 straight and 8 curved osteotomes

**OSTEOTOME
DIA. 100 MM SHARP TIP**

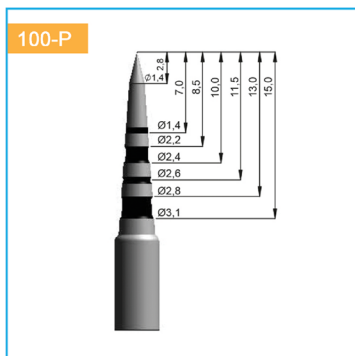

**OSTEOTOME
DIA. 160 MM**

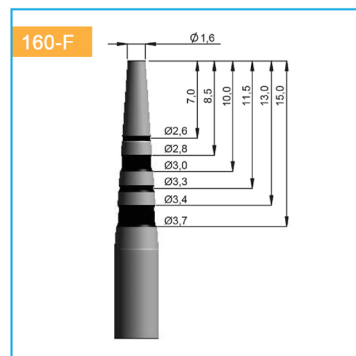

**OSTEOTOME
DIA. 230 MM**

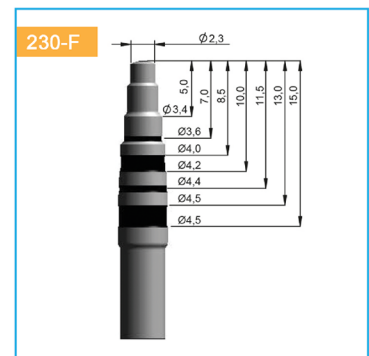

**OSTEOTOME
DIA. 300 MM**

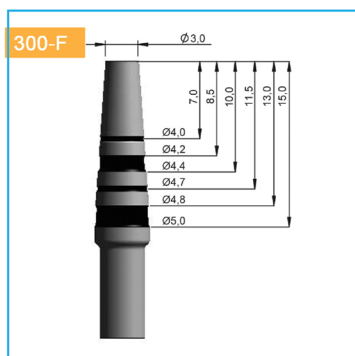

**OSTEOTOME
DIA. 360 MM**

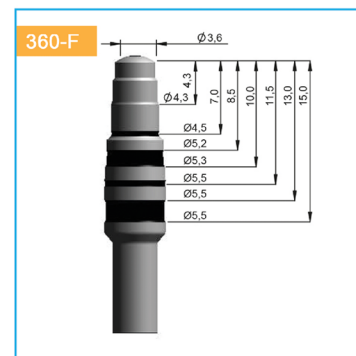

**OSTEOTOME
DIA. 100 MM**

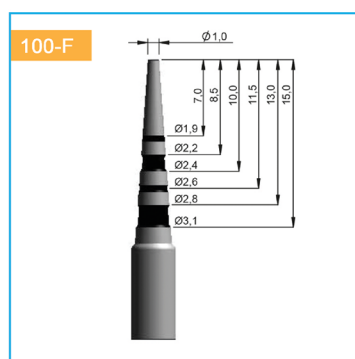

**OSTEOTOME
DIA. 200 MM**

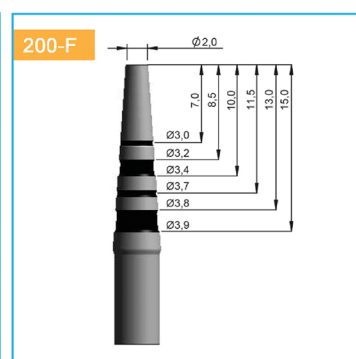

**OSTEOTOME
DIA. 330 MM**

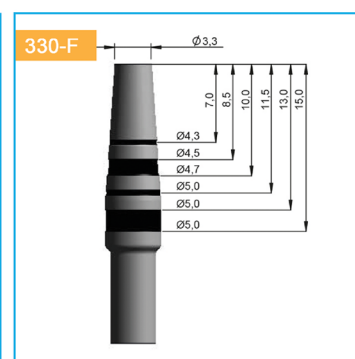

Surgical Procedure

Lateral bone compression during implant site preparation can improve the quality of type III bone turning it into type II bone offering more options to place implants and for immediate loading. The same is observed In type IV bone compressed into type III bone as can be found in maxillary molar region, especially when the bone width and height is insufficient.

After exposing the bone crest with a modified partial thickness flap using a surgical beaver, the edentulous bone crest is covered by the preserved suprabony connective tissue and the underlying periosteum. The implant site is first marked with the Osteotome 100P (sharp tip) **setting force 1 or 2 according bone density**. The maneuverability of the hand-piece and a clear field of view not cluttered by the irrigation will allow to choose the optimized axis of the implant site.



The implant site will be created expanding the bone tissue both laterally against the pre-existing lateral walls and apically. The osteotomy is progressively expanded with the force imparted to the osteotomes by the Magnetic Mallet with a maximum run of 1.1 mm at each pulse.

The sequence of the osteotomes to utilize has to be predetermined according the width and height of the implant site to prepare. For this surgical procedure ***the forces are set to 2 or 3 according bone density.***

The final diameter of the osteotomy is between 0.5 mm and 1.2mm underprepared depending on the local bone density and type of implant.

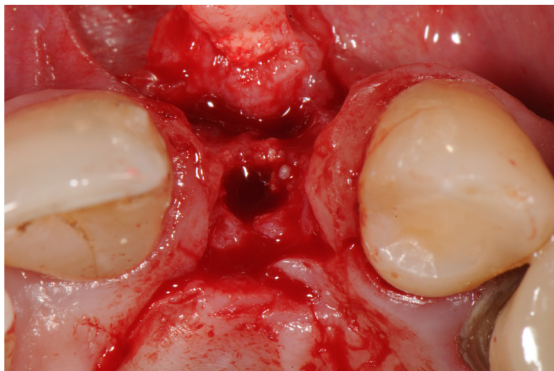

a

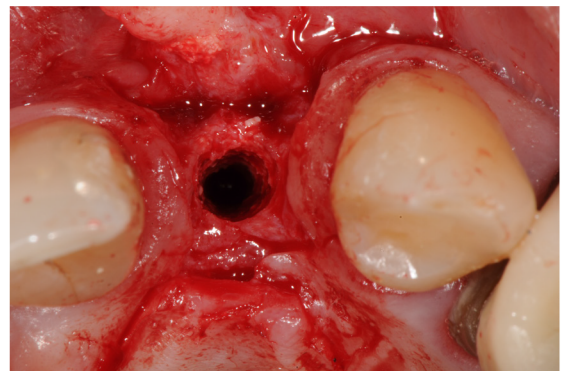

b

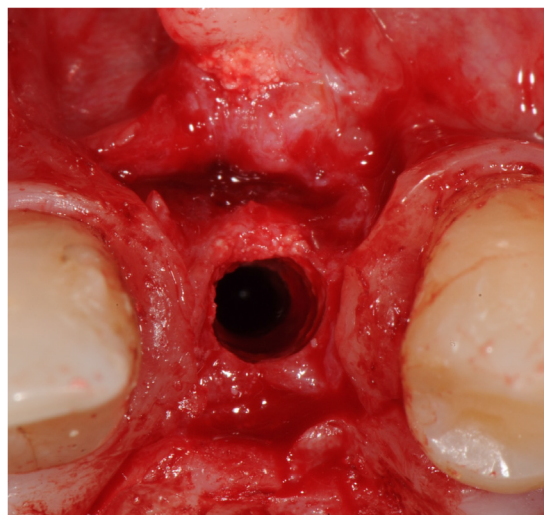

c

Fig 2.

A progressive in diameter bone expander starting from smallest instruments, were inserted in the previous osteotomy site.